

**General Information** Quick Selection Guide ..... page 7-2

**Products** 836E Pressure Switches ..... page 7-4

836E Nondisplay Pressure Switches ..... page 7-7

837E Temperature Switches ..... page 7-10



837E Nondisplay Temperature Switches ..... page 7-13



839E Flow Switches ..... page 7-15

840E Level Switches ..... page 7-17

**Accessories** Adaptors ..... page 7-6

Quick Selection Guide

	 <p><b>836E Pressure Switches</b></p>	 <p><b>836E Nondisplay Pressure Switches</b></p>	 <p><b>840E Level Switches</b></p>
<b>Features</b>	<ul style="list-style-type: none"> <li>• Microprocessor based with no moving parts for longer life and reduced downtime</li> <li>• Rugged, corrosion-resistant 316L stainless steel housing features an IP66 enclosure rating to withstand harsh industrial conditions</li> <li>• Operating pressures from -15...6000 psi (gauge)</li> <li>• Industry-leading four-digit 14-segment digital display</li> <li>• Independently programmable dual PNP N.O./N.C. outputs or 4...20 mA analog output</li> <li>• Stainless steel sensing element</li> </ul>	<ul style="list-style-type: none"> <li>• Microprocessor based with no moving parts for longer life and reduced downtime</li> <li>• Rugged, corrosion-resistant 304L stainless steel housing features an IP65 enclosure rating to withstand harsh industrial conditions</li> <li>• Operating pressures from 0...6000 psi (gauge)</li> <li>• 4...20 mA analog output</li> <li>• Stainless steel sensing element</li> </ul>	<ul style="list-style-type: none"> <li>• Liquid level switch used in tanks, containers and pipelines</li> <li>• On-site control using external LED display</li> <li>• Easy-to-install</li> <li>• Microprocessor based with no moving parts for longer life and reduced downtime</li> <li>• Rugged, corrosion-resistant 316L stainless steel housing features an IP67 enclosure rating to withstand harsh industrial conditions</li> <li>• DC PNP version with M12 connector</li> <li>• AC version with NPT 1/2 valve connector</li> <li>• 316L stainless steel sensing element</li> </ul>
<b>Applications</b>	<ul style="list-style-type: none"> <li>• Automotive industry</li> <li>• Machine tool</li> <li>• Injection molding machines</li> <li>• Hydraulics</li> <li>• Pneumatics</li> </ul>	<ul style="list-style-type: none"> <li>• Automotive industry</li> <li>• Machine tool</li> <li>• Injection molding machines</li> <li>• Hydraulics</li> <li>• Pneumatics</li> </ul>	<ul style="list-style-type: none"> <li>• Liquid level monitoring</li> <li>• Tanks, containers and pipelines</li> <li>• Filtering systems</li> <li>• Coolant and lubricant tanks</li> <li>• Pump protector</li> </ul>
<b>Supply Voltage</b>	<ul style="list-style-type: none"> <li>• 12...30V DC</li> </ul>	<ul style="list-style-type: none"> <li>• 12...30V DC</li> </ul>	<ul style="list-style-type: none"> <li>• DC PNP 10...35 V DC</li> <li>• AC 19...253 V AC</li> </ul>
<b>Output</b>	<ul style="list-style-type: none"> <li>• Dual PNP N.O./N.C. or 4...20 mA analog with single PNP N.O./N.C. programmable outputs</li> </ul>	<ul style="list-style-type: none"> <li>• 4...20 mA analog</li> </ul>	<ul style="list-style-type: none"> <li>• DC PNP</li> <li>• AC</li> </ul>
<b>Supply Current</b>	<ul style="list-style-type: none"> <li>• &lt;60 mA</li> </ul>	<ul style="list-style-type: none"> <li>• &lt;30 mA</li> </ul>	<ul style="list-style-type: none"> <li>• DC PNP &lt;15 mA</li> <li>• AC &lt;3.8 mA</li> </ul>
<b>Load Current</b>	<ul style="list-style-type: none"> <li>• 250 mA (each output)</li> </ul>	<ul style="list-style-type: none"> <li>• 250 mA (each output)</li> </ul>	<ul style="list-style-type: none"> <li>• 250 mA</li> </ul>
<b>Certifications</b>	<ul style="list-style-type: none"> <li>• cULus</li> <li>• CE Marked for all applicable directives</li> </ul>	<ul style="list-style-type: none"> <li>• CE Marked for all applicable directives</li> </ul>	<ul style="list-style-type: none"> <li>• CE Marked for all applicable directives</li> <li>• CSA C US</li> </ul>
<b>Additional Info</b>	<ul style="list-style-type: none"> <li>• See page 7-4</li> </ul>	<ul style="list-style-type: none"> <li>• See page 7-7</li> </ul>	<ul style="list-style-type: none"> <li>• See page 7-7</li> </ul>

 <p style="text-align: center;"><b>837E Temperature Switches</b></p>	 <p style="text-align: center;"><b>837E Nondisplay Temperature Switches</b></p>	 <p style="text-align: center;"><b>839E Flow Switches</b></p>
<ul style="list-style-type: none"> <li>• Microprocessor based with no moving parts for longer life and reduced downtime</li> <li>• Rugged, corrosion-resistant 316L stainless steel housing features an IP66 enclosure rating to withstand harsh industrial conditions</li> <li>• Media temperature range from -50...150°C (-58...302°F)</li> <li>• Industry-leading four-digit 14-segment digital display</li> <li>• Independently programmable dual PNP N.O./N.C. outputs or 4...20 mA analog output</li> <li>• 316L stainless steel probe</li> </ul>	<ul style="list-style-type: none"> <li>• Microprocessor based with no moving parts for longer life and reduced downtime</li> <li>• Rugged, corrosion-resistant 316L stainless steel housing features an IP66 enclosure rating to withstand harsh industrial conditions</li> <li>• Media temperature range from -50...150°C (-58...302°F)</li> <li>• 4...20 mA analog output PC programmable via the M12 connector</li> <li>• 316L stainless steel probe</li> </ul>	<ul style="list-style-type: none"> <li>• Microprocessor based with no moving parts for longer life and reduced downtime</li> <li>• Rugged, corrosion-resistant 316 stainless steel housing features an IP66 enclosure rating to withstand harsh industrial conditions</li> <li>• Flow range from 0.03...3 m/s (0.1...9.84 ft/s)</li> <li>• Industry-leading four-digit 14-segment digital display</li> <li>• Independently programmable dual PNP N.O./N.C. outputs or 4...20 mA analog output</li> <li>• 316L stainless steel probe</li> </ul>
<ul style="list-style-type: none"> <li>• Automotive industry</li> <li>• Machine tool</li> <li>• Hydraulics</li> <li>• Batch temperature control</li> </ul>	<ul style="list-style-type: none"> <li>• Automotive industry</li> <li>• Machine tool</li> <li>• Hydraulics</li> <li>• Batch temperature control</li> </ul>	<ul style="list-style-type: none"> <li>• Food and beverage</li> <li>• Pharmaceuticals</li> <li>• Water/wastewater</li> <li>• Hydraulics</li> </ul>
<ul style="list-style-type: none"> <li>• 12...30V DC</li> </ul>	<ul style="list-style-type: none"> <li>• 10...35V DC</li> </ul>	<ul style="list-style-type: none"> <li>• 18...30V DC</li> </ul>
<ul style="list-style-type: none"> <li>• Dual PNP N.O./N.C. or 4...20 mA analog with single PNP N.O./N.C. programmable outputs</li> </ul>	<ul style="list-style-type: none"> <li>• 4...20 mA analog</li> </ul>	<ul style="list-style-type: none"> <li>• Dual PNP N.O./N.C. or 4...20 mA analog with single PNP N.O./N.C. programmable outputs</li> </ul>
<ul style="list-style-type: none"> <li>• &lt;60 mA</li> </ul>	<ul style="list-style-type: none"> <li>• &lt;23 mA</li> </ul>	<ul style="list-style-type: none"> <li>• &lt;100 mA</li> </ul>
<ul style="list-style-type: none"> <li>• 250 mA (each output)</li> </ul>	<ul style="list-style-type: none"> <li>• 250 mA (each output)</li> </ul>	<ul style="list-style-type: none"> <li>• 250 mA (each output)</li> </ul>
<ul style="list-style-type: none"> <li>• cULus</li> <li>• CE Marked for all applicable directives</li> </ul>	<ul style="list-style-type: none"> <li>• cULus</li> <li>• CE Marked for all applicable directives</li> </ul>	<ul style="list-style-type: none"> <li>• cULus</li> <li>• CE Marked for all applicable directives</li> </ul>
<ul style="list-style-type: none"> <li>• See page 7-10</li> </ul>	<ul style="list-style-type: none"> <li>• See page 7-13</li> </ul>	<ul style="list-style-type: none"> <li>• See page 7-15</li> </ul>

## 836E Pressure Switches



### Features

- Microprocessor based with no moving parts for longer life and reduced downtime
- Rugged, corrosion-resistant 316L stainless steel housing features an IP66 enclosure rating to withstand harsh industrial conditions
- Operating pressures from -15...6000 psi (gauge)
- Industry-leading four-digit 14-segment digital display
- Independently programmable dual PNP NO/NC outputs or 4...20 mA analog output with single PNP NO/NC output
- Stainless steel sensing element

### Applications

- Automotive industry
- Machine tool
- Injection molding machines
- Hydraulics
- Pneumatics
- Food and beverage
- Pharmaceuticals

### Specifications

Certifications	cULus, CE Marked for all applicable directives, and 3 A authorized only with sanitary adaptor
Supply Voltage	12...30V DC
Output	Dual PNP N.O./N.C. or 4...20 mA analog with single PNP N.O./N.C.
Supply Current	<60 mA (no load)
Load Current, Max.	250 mA (per PNP output)
Analog Output Impedance	Max (Vsupply - 6.5V)/0.22 A
Accuracy	<0.5% of upper pressure range limit Analog Nonlinearity: <0.2% (as per limit point method)
Repeatability	<0.2% of upper pressure range limit
Long Term Drift	<0.15% per year
Media Temperature [C (F)]	-40...100° (-40...212°)
Operating Temperature [C (F)]	-40...85° (-40...185°)
Housing Material	316L stainless steel
Wetted Parts	316L stainless steel
Enclosure Type Rating	IP66 ①
Switch Cycles, Min.	>10,000,000
Over Pressure Limit (psi) ②	1.5 times MWP
Burst Pressure Limit	3 times MWP
Response Time	Switch Output: ≤20 ms; Analog Output: Rise Time: T <sub>90</sub> ≤200 ms; Analog Output: Settling Time: T <sub>99</sub> ≤500 ms

① Pressure sensors up to 60 psi are rated IP60.

② Maximum working pressure (MWP) is the maximum pressure that switches can tolerate for an indefinite period of time. Over pressure limit is the maximum pressure that switches can tolerate for a short period of time without sustaining permanent damage. Burst pressure limit is the maximum pressure that switches can tolerate without sustaining permanent damage or leakage.

**Solid-State Condition Sensing Switches**  
**836E Pressure Switches**

**Product Selection**

Process Connection	Pressure Range [psi]	Set Point Range [psi]	Reset Point Range [psi]	Max. Working Pressure [psi]①	Cat. No.	
					Dual PNP Output	420 mA Analog Output w/Single PNP Output②
1/4 inch NPT (female)	-15...15	-14.92+15	-15.00...14.92	40.5	836E-DA1CC1D4	836E-DC1CC1D4
	0...60	0.30...60	0...59.70	160.5	836E-DA1EL1D4	836E-DC1EL1D4
	0...150	0.75...150	0...149.25	400.5	836E-DA1EN1D4	836E-DC1EN1D4
	0...600	3.00...600	0...597.00	1600.5	836E-DA1EQ1D4	836E-DC1EQ1D4
	0...1,500	7.50...1,500	0...1,492.50	1600.5	836E-DA1ER1D4	836E-DC1ER1D4
	0...6,000	0.30...6000	0...5,970.00	6,000	836E-DA1EU1D4	836E-DC1EU1D4
SAE 7/16-20 UNF (female)	-15...15	-14.92...+15	-15.00...14.92	40.5	836E-DA1CC2D4	836E-DC1CC2D4
	0...60	0.30...60	0...59.70	160.5	836E-DA1EL2D4	836E-DC1EL2D4
	0...150	0.75...150	0...149.25	400.5	836E-DA1EN2D4	836E-DC1EN2D4
	0...600	3.00...600	0...597.00	1600.5	836E-DA1EQ2D4	836E-DC1EQ2D4
	0...1,500	7.50...1,500	0...1,492.50	1600.5	836E-DA1ER2D4	836E-DC1ER2D4
	0...6,000	0.30...6000	0...5,970.00	6,000	836E-DA1EU2D4	836E-DC1EU2D4
G1/4 BSPP (female)	-1...1 (bar)	-1.0...+1.03 (bar)	-1.03...1 (bar)	2.7 (bar)	836E-DA1CC3D4	836E-DC1CC3D4
	0...4 (bar)	0.02...4.14 (bar)	0...4 (bar)	10.7 (bar)	836E-DA1EL3D4	836E-DC1EL3D4
	0...10 (bar)	0.05...10.30 (bar)	0...10 (bar)	26.7 (bar)	836E-DA1EN3D4	836E-DC1EN3D4
	0...40 (bar)	0.21...41.38 (bar)	0...40 (bar)	106.7 (bar)	836E-DA1EQ3D4	836E-DC1EQ3D4
	0...100 (bar)	0.52...103.45 (bar)	0...100 (bar)	106.7 (bar)	836E-DA1ER3D4	836E-DC1ER3D4
	0...400 (bar)	2.07...413.79 (bar)	0...400 (bar)	400 (bar)	836E-DA1EU3D4	836E-DC1EU3D4
<b>Sanitary Connection</b>						
1...1.5 inch Clamp	0...150	0.75...150	0...149.25	400.5	836E-DA1ENBD4	836E-DC1ENBD4
	0...600	3.00...600	0...597.00	600	836E-DA1EQBD4	836E-DC1EQBD4
2 inch Clamp	0...150	0.75...150	0...149.25	400.5	836E-DA1ENC4	836E-DC1ENC4
	0...600	3.00...600	0...597.00	600	836E-DA1EQCD4	836E-DC1EQCD4
Base Switch (No Adaptor)	0...150	0.75...150	0...149.25	400.5	836E-DA1EN7D4	836E-DC1EN7D4
	0...600	3.00...600	0...597.00	600	836E-DA1EQ7D4	836E-DC1EQ7D4
Recommended cordset: 2 m (6.5 ft) 4-pin DC micro (straight) ③						889D-F4AC-2
Recommended cordset: 2 m (6.5 ft) 4-pin DC micro (right angle) ③						889D-R4AC-2

- ① Maximum working pressure (MWP) is the maximum pressure that switches can tolerate for an indefinite period of time. Over pressure limit is the maximum pressure that switches can tolerate for a short period of time without sustaining permanent damage. Burst pressure limit is the maximum pressure that switches can tolerate without sustaining permanent damage or leakage.
- ② Analog output version may be set up to output dual PNP NO/NC.
- ③ Additional cable lengths are available. Shielded cables may be used to protect analog signal quality in an electrically noisy environment—refer to the *On-Machine Connectivity* catalog for options.

# 836E Pressure Switches

## Approximate Dimensions [mm (in.)]

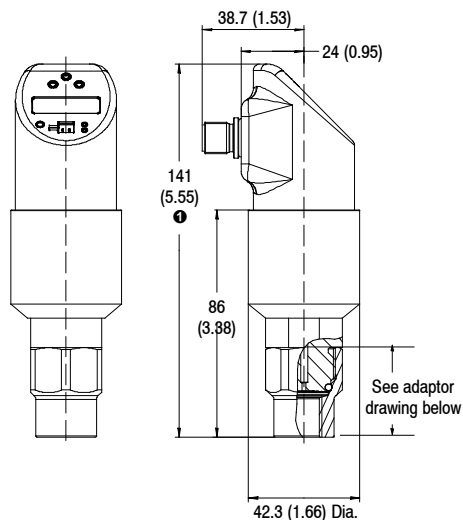

## Wiring Diagram

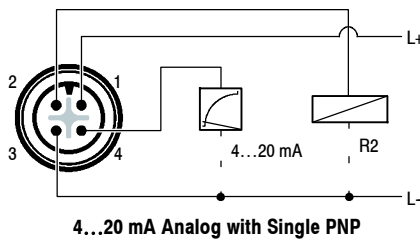
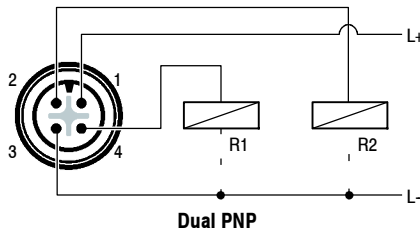

Note: Output 2 operates as diagnostic/break contact in DESINA mode.

① 145.2 (5.71) for 6000psi switch.

## Accessories

Description	Cat. No.	Description	Cat. No.
Configuration kit (includes converter cable and ReadWin 2000 software)	836E-NSR	7/16-20 UNF (male) adaptor	836E-NP75
1/4 in. NPT (female) adaptor	836E-NP71	G1/4 BSPP (male) adaptor	836E-NP76
7/16-20 UNF (female) adaptor	836E-NP72	1...1.5 inch sanitary clamp	836E-NH7B
G1/4 BSPP (female) adaptor	836E-NP73	2 inch sanitary clamp	836E-NH7C
1/4 in. NPT (male) adaptor	836E-NP74	O-ring (EPDM)	836E-NV1
		O-ring (fluorinated elastomer seal)	836E-NV2

Note: Maximum female adaptor pressure range = 1,450psi (100 bar).  
Maximum male adaptor pressure range = 580psi (40 bar).

## Female Adaptors

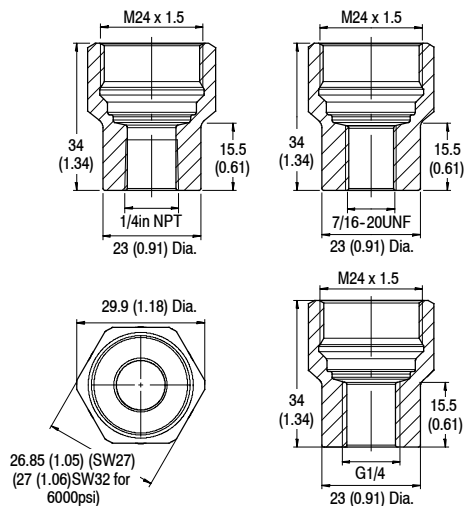

## Male Adaptors

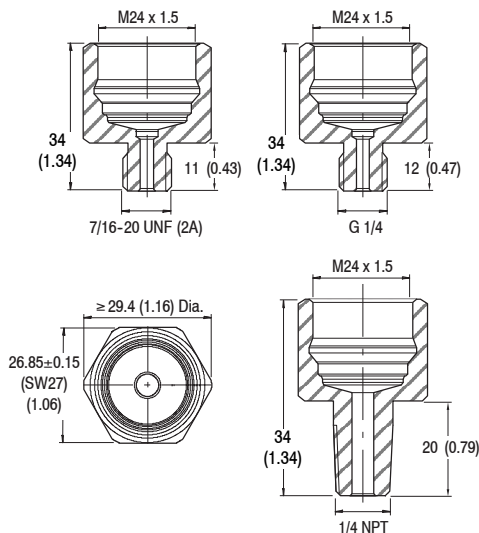

## Sanitary Connectors

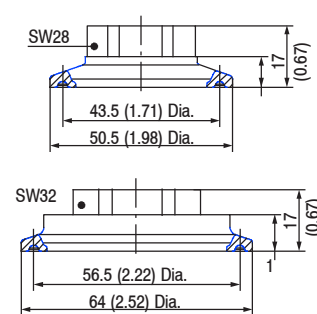



### Features

- Microprocessor based with no moving parts for longer life and reduced downtime
- Rugged, corrosion-resistant 304 stainless steel housing features an IP65 enclosure rating to withstand harsh industrial conditions
- Operating pressures from 0...6000 psi (gauge)
- 4...20 mA analog output
- 316L stainless steel sensing element

### Applications

- Automotive industry
- Machine tool
- Injection molding machines
- Hydraulics
- Pneumatics

### Specifications

Certifications	CE Marked for all applicable directives
Supply Voltage	12...30V DC
Output	4...20 mA analog
Supply Current	<30 mA
Analog Output Impedance	Max. (Vsupply - 12V)/0.02 A
Accuracy	<0.5% of upper pressure range limit analog nonlinearity
Repeatability	< 0.2% of upper pressure range limit
Long Term Drift	<0.15% per year
Media Temperature [C (F)]	-25...70° (-13...158°)
Operating Temperature [C (F)]	-25...70° (-13...158°) [ambient]
Storage Temperature [C (F)]	-40...85° (-40...185°)
Housing Material	304 stainless steel
Sensor Diaphragm	316L stainless steel
Enclosure Type Rating	IP65/NEMA 4
Over Pressure Limit (psi) ❶	1.5 times MWP
Response Time	2...5 ms

❶ Maximum working pressure (MWP) is the maximum pressure that switches can tolerate for an indefinite period of time. Over pressure limit is the maximum pressure that switches can tolerate for a short period of time without permanent damage.

# Solid-State Condition Sensing Switches

## 836E Nondisplay Pressure Switches

### Product Selection

Process Connection	Pressure Range [psi]	Max. Working Pressure [psi] ❶	Cat. No.
1/2 inch NPT (male)	0...500	1,000	836E-TD1EQ8-D4
	0...1,500	1,500	836E-TD1ER8-D4
	0...6,000	6,000	836E-TD1EU8-D4
1/4 inch NPT (male)	0...15	40	836E-TD1CC4-D4
	0...50	160	836E-TD1EL4-D4
	0...150	400	836E-TD1EN4-D4
	0...500	1,000	836E-TD1EQ4-D4
	0...1,500	1,500	836E-TD1ER4-D4
	0...6,000	6,000	836E-TD1EU4-D4
1/2 inch NPT (male) 1/4 inch NPT (female)	0...15	40	836E-TD1CC9-D4
	0...50	160	836E-TD1EL9-D4
	0...150	400	836E-TD1EN9-D4
	0...500	1,000	836E-TD1EQ9-D4
	0...1,500	1,500	836E-TD1ER9-D4
G1/2 (flush mount)	0...15	40	836E-TD1CC62-D4
	0...50	160	836E-TD1EL62-D4
	0...150	400	836E-TD1EN62-D4
	0...500	1,000	836E-TD1EQ62-D4
	0...1,500	1,500	836E-TD1ER62-D4
	0...6,000	6,000	836E-TD1EU62-D4
G1/4 (male)	0...15	40	836E-TD1CC6-D4
	0...50	160	836E-TD1EL6-D4
	0...150	400	836E-TD1EN6-D4
	0...500	1,000	836E-TD1EQ6-D4
	0...1,500	1,500	836E-TD1ER6-D4
	0...6,000	6,000	836E-TD1EU6-D4
Recommended cordset: 2 m (6.5 ft) 4-pin DC micro (straight) ❷			889D-F4AC-2
Recommended cordset: 2 m (6.5 ft) 4-pin DC micro (right angle) ❷			889D-R4AC-2

❶ Maximum working pressure (MWP) is the maximum pressure that switches can tolerate for an indefinite period of time. Over pressure limit is the maximum pressure that switches can tolerate for a short period of time without sustaining permanent damage.

❷ Additional cable lengths are available. Shielded cables may be used to protect analog signal quality in an electrically noisy environment—refer to the *On-Machine Connectivity* catalog for options.



**Approximate Dimensions [mm (in.)]**

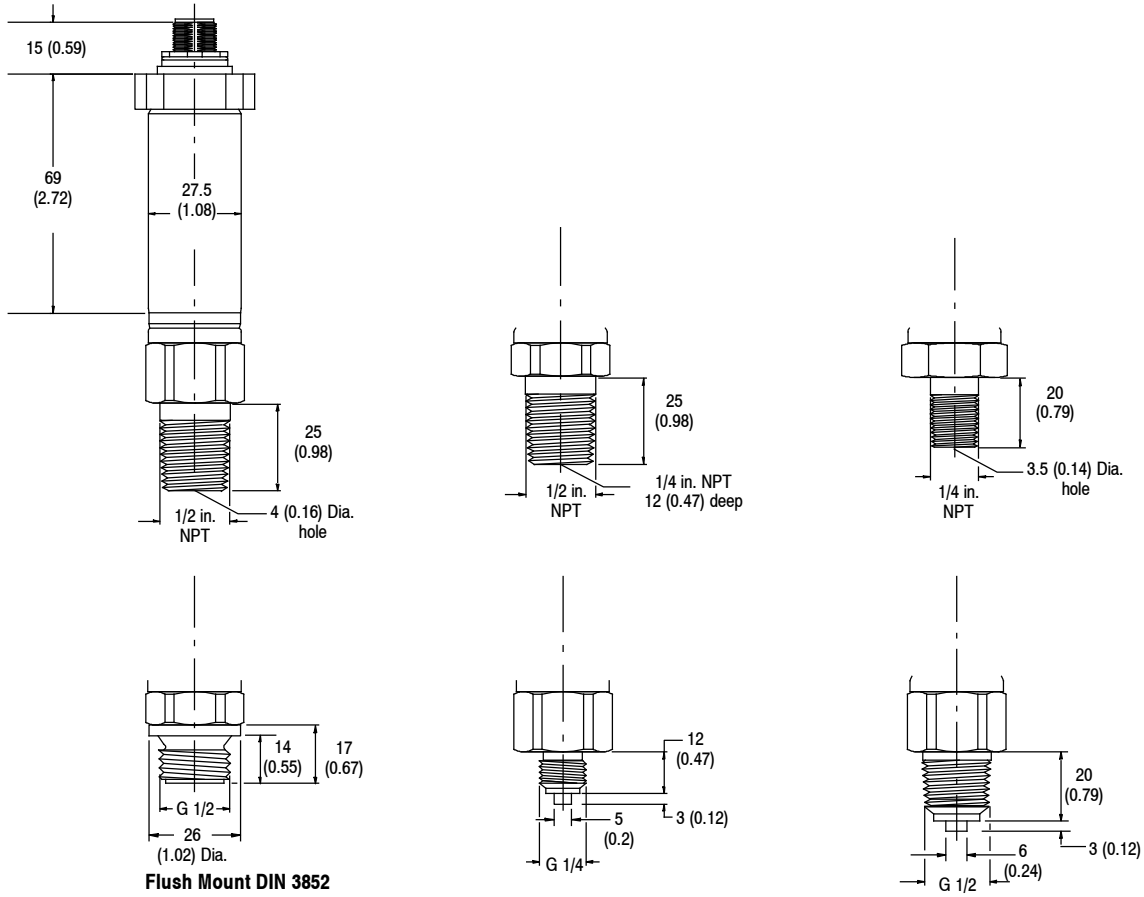

**Wiring Diagram**

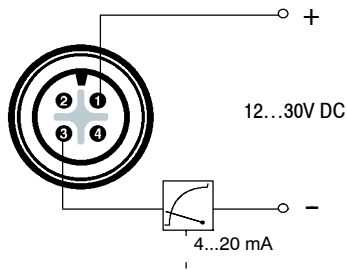

## 837E Temperature Switches



### Features

- Microprocessor based with no moving parts for longer life and reduced downtime
- Rugged, corrosion-resistant 316L stainless steel housing features an IP66 enclosure rating to withstand harsh industrial conditions
- Media temperature range from -50...150°C (-58...302°F)
- Operating temperatures from -40...85°C (-40...185°F)
- Industry-leading four-digit 14-segment digital display
- Independently programmable dual PNP N.O./N.C. outputs or 4...20 mA analog output with single PNP N.O./N.C. output
- Stainless steel probe

### Specifications

Certifications	cULus, CE Marked for all applicable directives, and 3 A authorized only with sanitary adaptor
Supply Voltage	12...30V DC
Output	Dual PNP N.O./N.C. or 4...20 mA analog output with single PNP N.O./N.C.
Supply Current	<60 mA (no load)
Load Current, Max.	250 mA (per PNP output)
Analog Output Impedance	Max. $(V_{supply} - 6.5V)/0.22 A$
Accuracy	<0.2°C
Repeatability	<0.1°C
Temperature Drift	<0.1°C per year
Media Temperature [C (F)]	-50...150° (-58...302°)
Operating Temperature [C (F)]	-40...85° (-40...185°)
Housing Material	316 stainless steel
Wetted Parts	316L stainless steel
Enclosure Type Rating	IP66
Switch Cycles, Min.	>10,000,000
Response Time	Switch Output: $\leq 20$ ms Analog Output: Rise Time: $T_{90} \leq 200$ ms Analog Output: Settling Time: $T_{99} \leq 500$ ms

### Applications

- Automotive industry
- Machine tool
- Hydraulics
- Batch temperature control
- Food and beverage
- Pharmaceuticals

**Product Selection**

Process Connection	Set Point Range [C (F)]	Reset Point Range [C (F)]	Probe Length	Cat. No.	
				Dual PNP Output	4...20 mA Analog Output w/Single PNP Output <sup>①</sup>
1/4 inch NPT (Male)	-49...150° (-57...302°)	-50...149.5° (-58...301°)	50 (1.96 in.)	837E-DA1BN1A1D4	837E-DC1BN1A1D4
	-49...150° (-57...302°)	-50...149.5° (-58...301°)	100 (3.93 in.)	837E-DA1BN1A2D4	837E-DC1BN1A2D4
	-49...150° (-57...302°)	-50...149.5° (-58...301°)	200 (7.87 in.)	837E-DA1BN1A4D4	837E-DC1BN1A4D4
1/2 inch NPT (Male)	-49...150° (-56.2...302°)	-50...149.5° (-58...301.1°)	50 (1.96 in.)	837E-DA1BN2A1D4	837E-DC1BN2A1D4
	-49...150° (-57...302°)	-50...149.5° (-58...301.1°)	100 (3.93 in.)	837E-DA1BN2A2D4	837E-DC1BN2A2D4
	-49...150° (-57...302°)	-50...149.5° (-58...301°)	200 (7.87 in.)	837E-DA1BN2A4D4	837E-DC1BN2A4D4
G1/4 BSPP	-49...150° (-57...302°)	-50...149.5° (-58...301°)	50 (1.96 in.)	837E-DA1BN3A1D4	837E-DC1BN3A1D4
	-49...150° (-57...302°)	-50...149.5° (-58...301°)	100 (3.93 in.)	837E-DA1BN3A2D4	837E-DC1BN3A2D4
	-49...150° (-57...302°)	-50...149.5° (-58...301°)	200 (7.87 in.)	837E-DA1BN3A4D4	837E-DC1BN3A4D4
G1/2 BSPP	-49...150° (-57...302°)	-50...149.5° (-58...301°)	50 (1.96 in.)	837E-DA1BN4A1D4	837E-DC1BN4A1D4
	-49...150° (-57...302°)	-50...149.5° (-58...301°)	100 (3.93 in.)	837E-DA1BN4A2D4	837E-DC1BN4A2D4
	-49...150° (-57...302°)	-50...149.5° (-58...301°)	200 (7.87 in.)	837E-DA1BN4A4D4	837E-DC1BN4A4D4
<b>Sanitary Connection</b>					
1...1.5 inch Clamp	-49...150° (-57...302°)	-50...149.5° (-58...301°)	50 mm (1.96 in.)	837E-DA1BNBA1D4	837E-DC1BNBA1D4
	-49...150° (-57...302°)	-50...149.5° (-58...301°)	100 mm (3.93 in.)	837E-DA1BNBA2D4	837E-DC1BNBA2D4
	-49...150° (-57...302°)	-50...149.5° (-58...301°)	200 mm (7.87 in.)	837E-DA1BNBA4D4	837E-DC1BNBA4D4
2 inch Clamp	-49...150° (-57...302°)	-50...149.5° (-58...301°)	50 mm (1.96 in.)	837E-DA1BNCA1D4	837E-DC1BNCA1D4
	-49...150° (-57...302°)	-50...149.5° (-58...301°)	100 mm (3.93 in.)	837E-DA1BNCA2D4	837E-DC1BNCA2D4
	-49...150° (-57...302°)	-50...149.5° (-58...301°)	200 mm (7.87 in.)	837E-DA1BNCA4D4	837E-DC1BNCA4D4
Base Switch	-49...150° (-57...302°)	-50...149.5° (-58...301°)	50 mm (1.96 in.)	837E-DA1BN7A1D4	837E-DC1BN7A1D4
	-49...150° (-57...302°)	-50...149.5° (-58...301°)	100 mm (3.93 in.)	837E-DA1BN7A2D4	837E-DC1BN7A2D4
	-49...150° (-57...302°)	-50...149.5° (-58...301°)	200 mm (7.87 in.)	837E-DA1BN7A4D4	837E-DC1BN7A4D4
Recommended cordset: 2 m (6.5 ft) 4-pin DC micro (straight) <sup>②</sup>					889D-F4AC-2
Recommended cordset: 2 m (6.5 ft) 4-pin DC micro (right angle) <sup>②</sup>					889D-R4AC-2

① Analog output version may be set up to output dual PNP N.O./N.C.

② Additional cable lengths are available. Shielded cables may be used to protect analog signal quality in an electrically noisy environment—refer to the *On-Machine™ Connectivity* catalog for options.

**Approximate Dimensions [mm (in.)]**

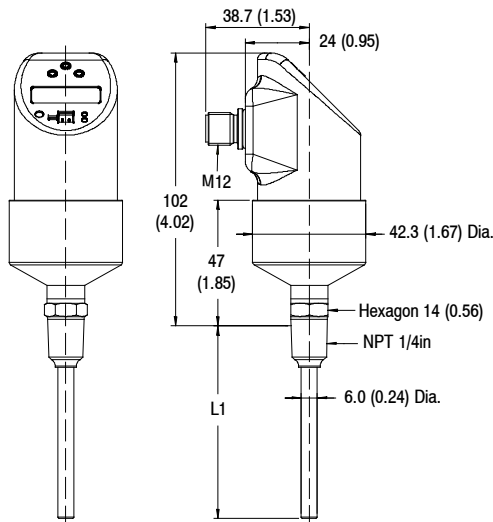

**Wiring Diagram**

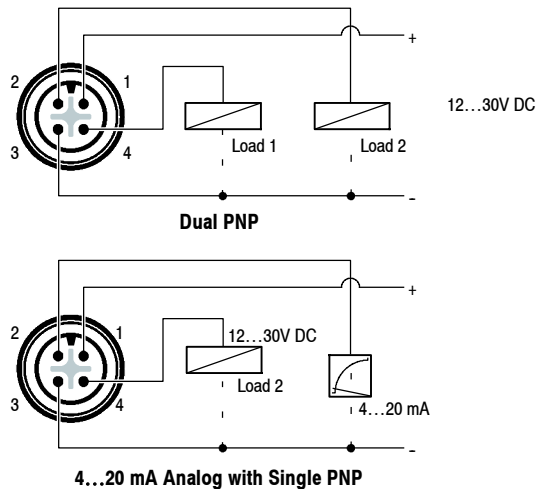

**Note:** Output 2 operates as diagnostic/break contact in DESINA mode.

## 837E Temperature Switches

### Accessories

Description	Cat. No.
Configuration kit (includes converter cable and ReadWin 2000 software)	836E-NSR
1...1.5 inch sanitary clamp	836E-NH7B
2 inch sanitary clamp	836E-NH7C

### Sanitary Connectors

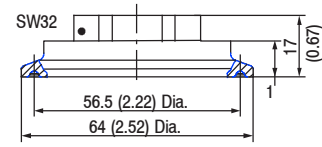
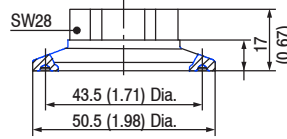



### Features

- Microprocessor based with no moving parts for longer life and reduced downtime
- Rugged, corrosion-resistant 316L stainless steel housing features an IP67 enclosure rating to withstand harsh industrial conditions
- Media temperature range from -50...150°C (-58...302°F)
- Operating temperatures from -40...85°C (-40...185°F)
- 4...20 mA analog output PC programmable via the M12 connector
- Stainless steel probe

### Applications

- Automotive industry
- Machine tool
- Hydraulics
- Batch temperature control
- Food and beverage
- Pharmaceuticals

### Specifications

Certifications	cULus, CE Marked for all applicable directives, and 3 A authorized only with sanitary adaptor
Supply Voltage	10...35V DC
Output	4...20 mA analog
Supply Current	<23 mA (no load)
Analog Output Impedance	Max. $(V_{\text{supply}} - 10V)/0.23 \text{ A}$
Accuracy	<0.2°C
Repeatability	<0.1°C
Temperature Drift	<0.1°C per year
Media Temperature [C (F)]	-50...150° (-58...302°)
Operating Temperature [C (F)]	-40...85° (-40...185°)
Housing Material	316 stainless steel
Wetted Parts	316L stainless steel
Enclosure Type Rating	IP67
Switch Cycles, Min.	>10,000,000
Response Time	< 3 s

# Solid-State Condition Sensing Switches

## 837E Nondisplay Temperature Switches

### Product Selection

Process Connection	Media Temperature [C (F)]	Probe Length	Cat. No.
			4...20 mA Analog Output
1/4 inch NPT (Male)	-50...150° (-58...302°)	50 mm (1.96 in.)	837E-TD1BN1A1-D4
	-50...150° (-58...302°)	100 mm (3.93 in.)	837E-TD1BN1A2-D4
	-50...150° (-58...302°)	200 mm (7.87 in.)	837E-TD1BN1A4-D4
1/2 inch NPT (Male)	-50...150° (-58...302°)	50 mm (1.96 in.)	837E-TD1BN2A1-D4
	-50...150° (-58...302°)	100 mm (3.93 in.)	837E-TD1BN2A2-D4
	-50...150° (-58...302°)	200 mm (7.87 in.)	837E-TD1BN2A4-D4
G1/4 BSPP	-50...150° (-58...302°)	50 mm (1.96 in.)	837E-TD1BN3A1-D4
	-50...150° (-58...302°)	100 mm (3.93 in.)	837E-TD1BN3A2-D4
	-50...150° (-58...302°)	200 mm (7.87 in.)	837E-TD1BN3A4-D4
<b>Sanitary Connection</b>			
1...1.5 inch Clamp	-50...150° (-58...302°)	50 mm (1.96 in.)	837E-TD1BNBA1-D4
	-50...150° (-58...302°)	100 mm (3.93 in.)	837E-TD1BNBA2-D4
	-50...150° (-58...302°)	200 mm (7.87 in.)	837E-TD1BNBA4-D4
2 inch Clamp	-50...150° (-58...302°)	50 mm (1.96 in.)	837E-TD1BNCA1-D4
	-50...150° (-58...302°)	100 mm (3.93 in.)	837E-TD1BNCA2-D4
	-50...150° (-58...302°)	200 mm (7.87 in.)	837E-TD1BNCA4-D4
Recommended cordset: 2 m (6.5 ft) 4-pin DC Micro (straight) ①			889D-F4AC-2
Recommended cordset: 2 m (6.5 ft) 4-pin DC Micro (right angle) ①			889D-R4AC-2

① Additional cable lengths are available. Shielded cables may be used to protect analog signal quality in an electrically noisy environment—refer to the *On-Machine Connectivity* catalog for options.

### Approximate Dimensions [mm (in.)]

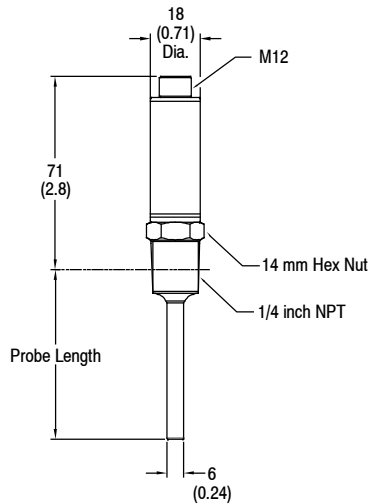

### Wiring Diagram

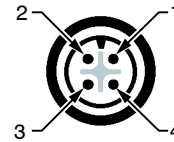

Pin No.	Description	Wire Color
1	Power supply 10...35V DC, current output 4...20 mA	Brown
2	Connection of PC configuration cable, shortened pin	White
3	Power supply 0V DC, current output 4...20 mA	Blue
4	Connection of PC configuration cable, shortened pin	Black

### Accessories

Description	Cat. No.
Configuration kit (includes converter cable and ReadWin 2000 software)	836E-NSR
Cable adaptor, PC programming	836E-NSRT
1...1.5 inch sanitary clamp	836E-NH7B
2 inch sanitary clamp	836E-NH7C

### Sanitary Connectors

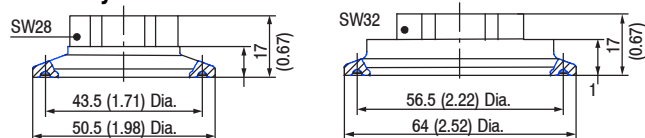



### Features

- Microprocessor based with no moving parts for longer life and reduced downtime
- Rugged, corrosion-resistant 316 stainless steel housing features an IP66 enclosure rating to withstand harsh industrial conditions
- Flow rates of liquid media (calorimetric measuring principle) in the range from 0.03...3 m/s (0.1...9.84 ft/s)
- Industry leading four-digit 14-segment digital display
- Dual N.O./N.C. programmable PNP outputs or 4...20 mA analog output with single PNP output
- Stainless steel probe

### Applications

- Food and beverage
- Pharmaceuticals
- Water/Wastewater
- Hydraulics

### Specifications

Certifications	cULus, CE Marked for all applicable directives, and 3 A authorized only with sanitary adaptor			
Supply Voltage	18...30V DC			
Output	Dual PNP N.O./N.C. or 4...20 mA analog output with single PNP N.O./N.C.			
Supply Current	<100 mA			
Load Current, Min.	250 mA			
Temperature Accuracy	2 K (3.6 F)			
Temperature Repeatability	1 K ( 1.8 F)			
Operating Range	Liquids from 0.03...3 m/s (0.1... 9.84 ft/s) Mass flow as a relative value between 0 and 100%			
Media Temperature [C (F)]	-20...85° (-4...185°)			
Housing Material	316 stainless steel			
Enclosure Type Rating	IP66			
Switch Cycles, Min.	>10,000,000			
Flow Accuracy	Measuring Range— m/s (f/s)	Repeatability	Influence of Medium Temperature❶	Influence of Ambient Temperature
	0.03...0.5 (0.1...1.6)	2%	0.05%/K	0.04%/K
	0.03...1 (0.1...3.28)	3%	0.10%/K	0.05%/K
	0.03...2 (0.1...6.56)	5%	0.15%/K	0.10%/K
	0.03...3 (0.1...9.84)	10%	0.25%/K	0.30%/K

❶ The values indicated only apply to the device itself without taking the temperature-dependent change of the thermo-physical properties of the medium into account. For this reason, we recommend you commission the device at the process temperature and set the switch points (learn function).

**Note:** The temperature should be within  $\pm 10$  degrees of the calibration temperature for reliable results.

# 839E Flow Switches

## Product Selection

Process Connection	Measuring Range	Response Time	Probe Length	Cat. No.	
				Dual PNP Output	4...20 mA Analog Output with Single PNP Output <sup>①</sup>
1/4 inch NPT (Male)	Liquids from 0.03...3 m/s (0.1... 9.84 ft/s) Mass flow as a relative value between 0 and 100%	6...12 seconds	30 mm (1.18 in)	839E-DA1BA1A3-D4	839E-DC1BA1A3D4
			100 mm (3.93 in)	839E-DA1BA1A2-D4	839E-DC1BA1A2D4
1/2 inch NPT (Male)			30 mm (1.18 in)	839E-DA1BA2A3D4	839E-DC1BA2A3D4
			100 mm (3.96 in)	839E-DA1BA2A2D4	839E-DC1BA2A2D4
G1/4 BSPP			30 mm (1.18 in)	839E-DA1BA3A3D4	839E-DC1BA3A3D4
			100 mm (3.96 in)	839E-DA1BA3A2D4	839E-DC1BA3A2D4
G1/2 BSPP			30 mm (1.18 in)	839E-DA1BA4A3D4	839E-DC1BA4A3D4
			100 mm (3.96 in)	839E-DA1BA4A2D4	839E-DC1BA4A2D4
<b>Sanitary Connection</b>					
1...1.5 inch Clamp	Liquids from 0.03...3 m/s (0.1... 9.84 ft/s) Mass flow as a relative value between 0 and 100%	6...12 seconds	30 mm (1.18 in)	839E-DA1BABA3D4	839E-DC1BABA3D4
			100 mm (3.96 in)	839E-DA1BABA2D4	839E-DC1BABA2D4
2 inch Clamp			30 mm (1.18 in)	839E-DA1BACA3D4	839E-DC1BACA3D4
			100 mm (3.96 in)	839E-DA1BACA2D4	839E-DC1BACA2D4
Base Switch			30 mm (1.18 in)	839E-DA1BA7A3D4	839E-DC1BA7A3D4
			100 mm (3.96 in)	839E-DA1BA7A2D4	839E-DC1BA7A2D4
Recommended cordset: 2 m (6.5 ft) 4-pin DC micro (straight)					889D-F4AC-2
Recommended cordset: 2 m (6.5 ft) 4-pin DC micro (right angle)					889D-R4AC-2

① Analog output version may be set up to output dual PNP N.O./N.C.

## Approximate Dimensions [mm (in.)]

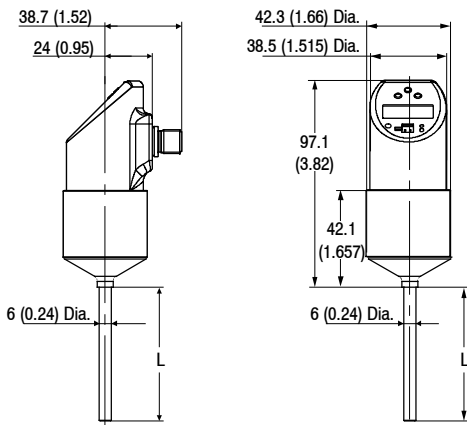

## Wiring Diagram

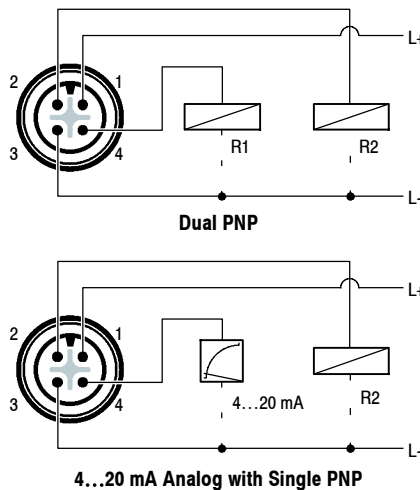

## Accessories

Description	Cat. No.
Configuration kit (includes converter cable and ReadWin 2000 software)	836E-NSR
1...1.5 in. sanitary clamp	836E-NH7B
2 in. sanitary clamp	836E-NH7C

## Sanitary Connectors

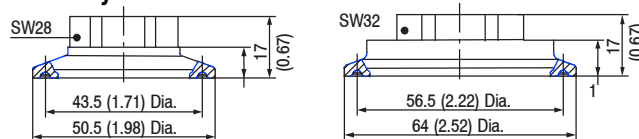





### Features

- Liquid level switch used in tanks, containers and pipelines
- On-site control using external LED display
- Easy-to-install
- Microprocessor based with no moving parts for longer life and reduced downtime
- Rugged, corrosion-resistant 316L stainless steel housing features IP66/67 rating for DC type and IP65 for AC type enclosure for various industrial conditions
- DC PNP version with M12 connector
- AC version with NPT 1/2 valve connector
- 316L stainless steel sensing element

### Applications

- Liquid level monitoring
- Tanks, containers and pipelines
- Filtering systems
- Coolant and lubricant tanks
- Pump protector

### Specifications

Certifications	CE Marked for all applicable directives, CSA C US	
Housing Material	316L stainless steel	
<b>Power Supply</b>		
DC-PNP with M12 connector	10...35 V DC < 825 mW < 15 mA	Supply voltage Power consumption Current consumption
AC with NPT 1/2 valve connector	19...253 V AC < 819 mW < 3.8 mA	Supply voltage Power consumption Current consumption
<b>Performance Characteristics</b>		
Switching Delay	0.5 s when covering 1.0 s when free	
Resolution [mm (in.)]	< 0.5 (0.02)	
Maximum Error [mm (in.)]	13.0 +/- 1 (0.51 +/- 0.04)	
Repeatability [mm (in.)]	+/- 0.5 (+/- 0.02)	
Hysteresis [mm (in.)]	3.0 +/- 0.5 (0.12 +/- 0.02)	
Settling Time	< 2 s	
Ambient Temperature Range [C (F)]	-40...70° (-40...+158°)	
Storage Temperature Range [C (F)]	-40...85° (-40...+185°)	
Process Temperature Range [C (F)]	-40...100° (-40...+212°)	
Process Pressure	-14.5...580 psi	
Degree of Protection	NEMA 4X (IP66/67) NEMA 4 (IP65)	DC-M12 Connector AC-Valve Connector
Media	Liquid	
Density	> 0.7 SGU	
Viscosity	1...10000 cSt	
Gas Content	Stagnant Mineral Water	
Solids Content [mm (in.)]	5 Dia. (<0.20)	

# 840E Level Switches

## Product Selection

Process Connection	Cat. No.	
	DC- PNP	AC
1/2 inch NPT (male)	840E-TB1B1A1D4	840E-TB2B1A1E4
3/4 inch NPT (male)	840E-TB1B2A1D4	840E-TB2B2A1E4
G 1/2 inch (male)	840E-TB1B3A1D4	840E-TB2B3A1E4
Recommended cordset: 2 m (6.5 ft) 4-pin DC micro (straight) ❶	889D-F4AC-2	
Recommended cordset: 2 m (6.5 ft) 4-pin DC micro (right angle) ❶	889D-R4AC-2	
Optional cordset 2 m (6.5 ft) DIN valve ❶		889V-RZ3ABE-2

❶ Additional cable lengths are available. Shielded cables may be used to protect analog signal quality in an electrically noisy environment—refer to the *On-Machine Connectivity* catalog for options.

## Approximate Dimensions [mm (in.)]

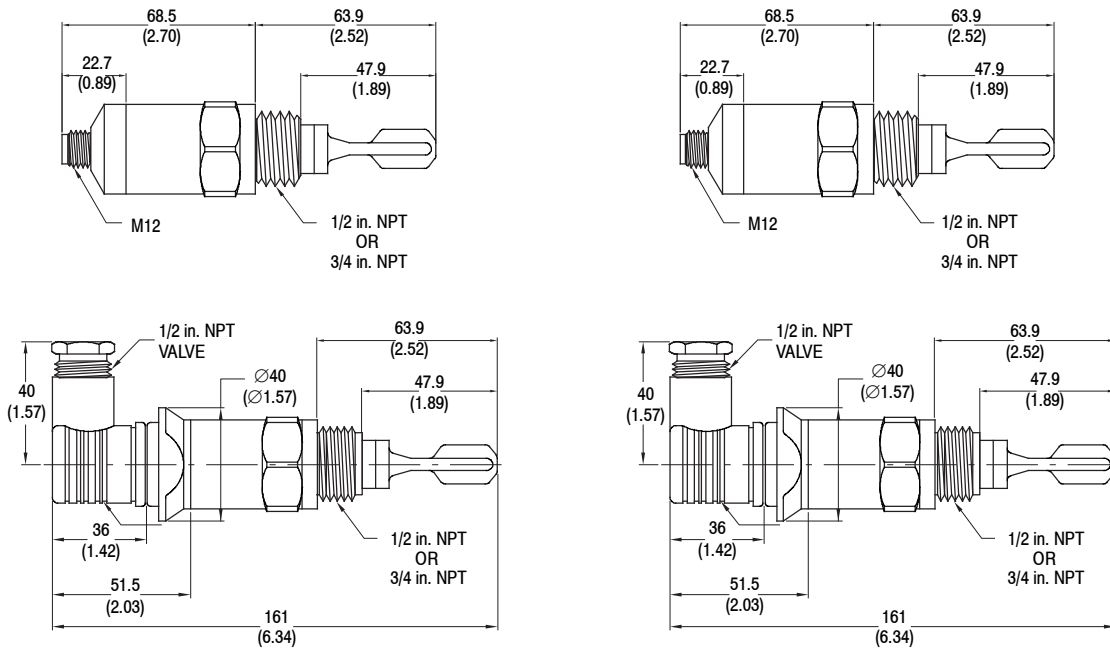

**Wiring Diagram**

DC PNP with M12 Connector

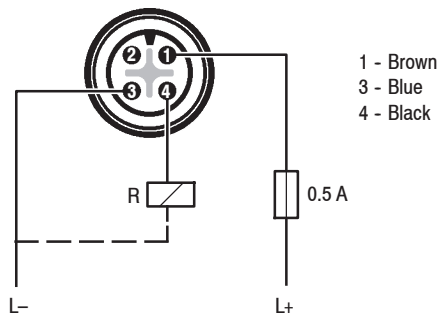
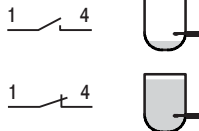
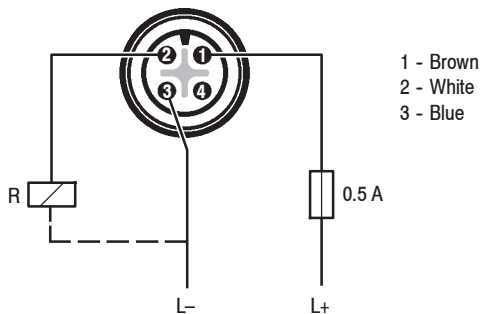
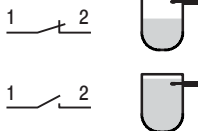

AC with Valve Connector NPT 1/2 inch

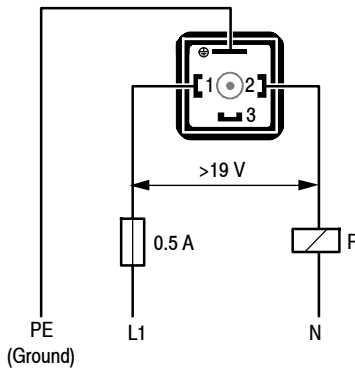
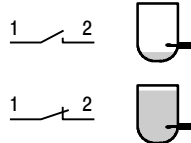
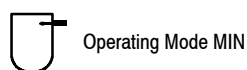
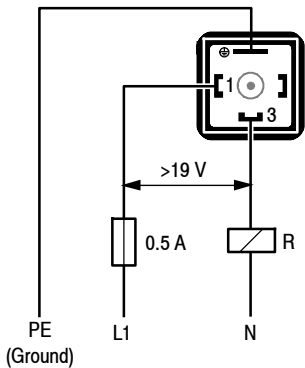
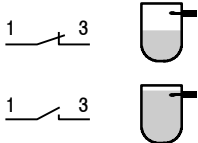
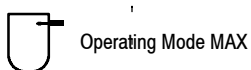

**Optional Cordset DIN Valve**

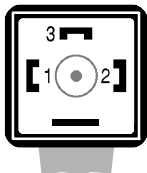

- 1 Brown
- 2 Blue
- 3 Black
- GND Yellow/Green

Notes

---